

GL350

12 to 750 Vdc/Vac

Sealed HV DC/AC Contactor - 350Amp Power Switching (Replace GL200)
RoHS Compliant



● **Features**

<ul style="list-style-type: none"> • Ceramic to metal seal rated to 175°C-Reduced risk of fire or meltdown in over-current conditions.
<ul style="list-style-type: none"> • Hermetic Seal – Designed to meet UL1604 for Class I & II, Div 2 and Class III for use in hazardous locations, IP67 for temporary water immersion for 30 min, SAE J1171 - external ignition protection, and ISO8846 for protection against ignition around flammable gasses.
<ul style="list-style-type: none"> • High Efficiency Coils –Coil with PWM economizer can lower power cost and it limits back EMF to 0V. The contactor can keep contact with very low coil power supply.
<ul style="list-style-type: none"> • No Exposed Coil Electronics – The GL350 can operate almost anywhere, even under water – the coil electronics is fully sealed.
<ul style="list-style-type: none"> • Fully RoHS Compliant – The GL350 is fully compliant and is better for the environment and future generations.

● **Product specifications**

Parameter	Ratings
Contact Arrangement (main)	SPST-NO
Rated Operating Voltage	12-750VDC/VAC
Rated carrying current	350A (400Kcmil cable- 203mm ² cross-section area)
Max carrying current (1time)	1 Second ,2000A, 60 Seconds, 600A, 600 Seconds, 400A See Figure 2. Current carrying capacity
Switching Capacity	See Figure 1. Power switching capacity for resistive load
Max cut-off current	2000A@320VDC, 1 time
Contact Resistance Max @ rated carry current Typical @ 350A	0.4mΩ 0.3mΩ
Mechanical Life	300, 000 Cycles
Operate time, 25°C Close (includes bounce) Max Close (includes bounce) Typical Bounce on close, Max Release time (includes arc time at max. break current)	20ms 13 ms 7 ms 12 ms
Contact Arrangement (Auxiliary)	SPST-NO (The auxiliary contact is mechanically linked to the main power contacts.)
Auxiliary contact rating	2A@24VDC
Minimum current and voltage for Auxiliary contact	100mA@8V
Insulation Resistance at 500VDC	100 MΩ (50 MΩ after life test)
Dielectric at sea level (leakage < 1mA)	2200 VRMS
Shock (Saw tooth or 1/2 Sine,11ms)	20G's
Vibration, Sinusoidal (10-2000 Hz peak)	20G's
Operating ambient Temp Range	-55-85°C
Storage ambient Temp Range	-55°C-125°C
Weight, Typical	0.38kg/(0.84Lb) (without nuts/washers)

● **Power switching capacity for resistive load**

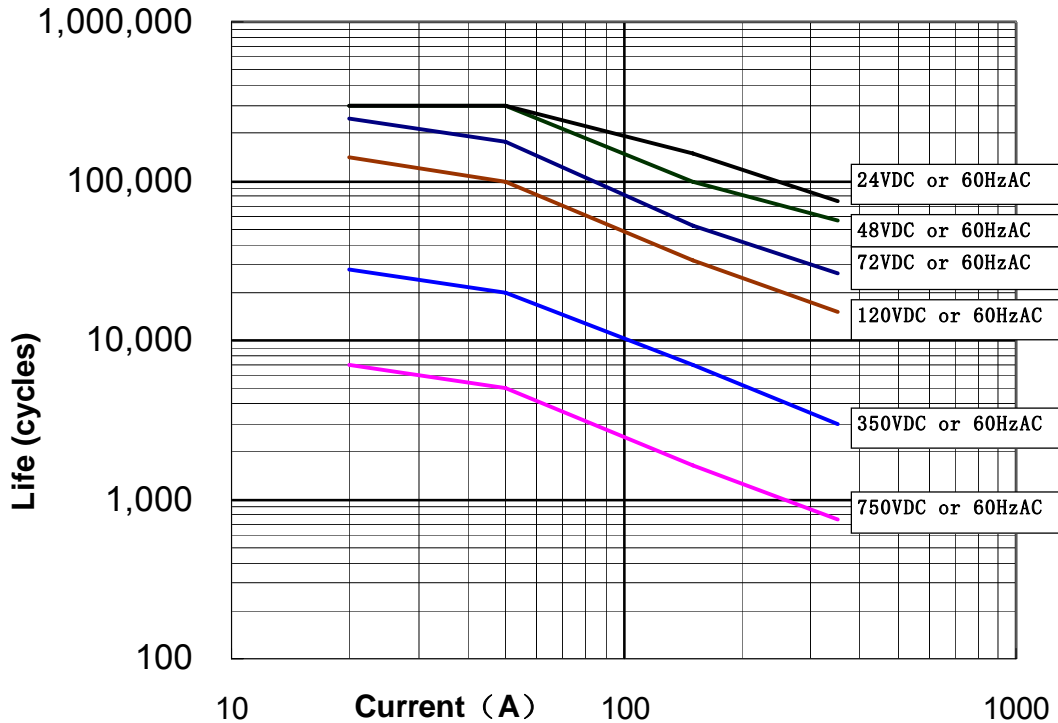

Figure 1 . Power switching capacity for resistive load

Note:

1. Electrical life rating is based on resistive load with 27 μ H maximum inductance in circuit. Because your application may be different, we suggest you test the contactor in your circuit to verify life is as required. End of life is defined as when the dielectric, insulation resistance or contact resistance exceeds the specifications listed.
2. Contactor is connected by 400 KCmil cables (203mm² cross-section area).

● **Current carrying capacity**

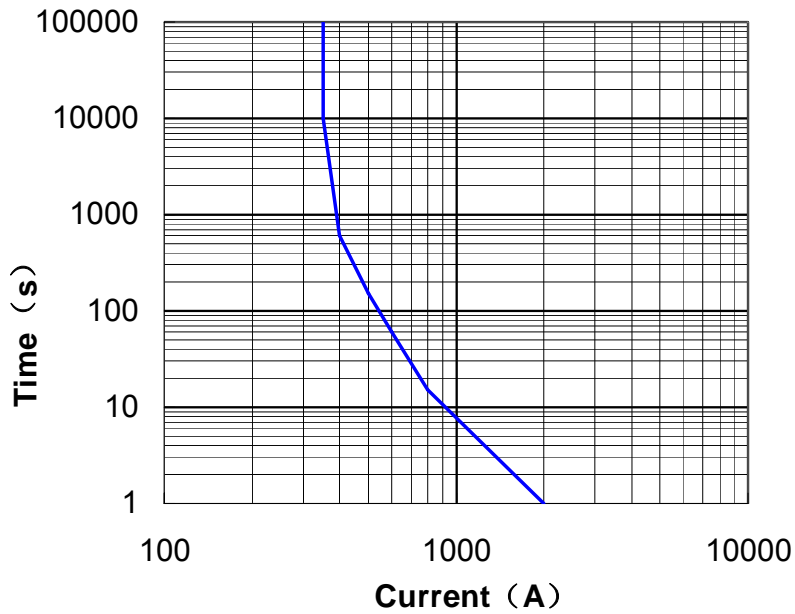

Figure 2. Current Carrying capacity

● **Coil ratings**

Coil P/N Designation	A or 1	D
Coil Voltage (Will operate)	10-36Vdc	32-95Vdc
Coil Voltage (Max)	36Vdc	95Vdc
In-Rush Current Max (100 ms) – Amps	3.6A	0.9A
Hold Current after in-rush (Avg.) - Amps	0.13A@12Vdc, 0.07A@24Vdc	0.04A@48Vdc
Pick-up Voltage @ 25C, Max	8.5V	32V
Dropout Voltage @ 25C, Min	4.5V	20V

Ratings are valid over temperature range .

● **Part number system**

GL350	A	A	A	N	A



Coil Terminal Connector: N=None
Mounting & Power Terminals: A=Bottom Mount & Male 10mm X M8 Terminals

● **Electrical load life ratings for typical EV application**

Power voltage	320VDC
Make life at 90% capacitive pre-charge	50,000 cycles (See figure 3)
Make life at 80% capacitive pre-charge	50 cycles
Make/break life at reversed 200A	12 cycles
Maximum break capacity (positive direction)	2000A, one time. Does not meet dielectric and IR after test.

Note:

1. Resistive load includes inductance $L \leq 27\mu\text{H}$.
2. Life based on projected Weibull life with 95% reliability.

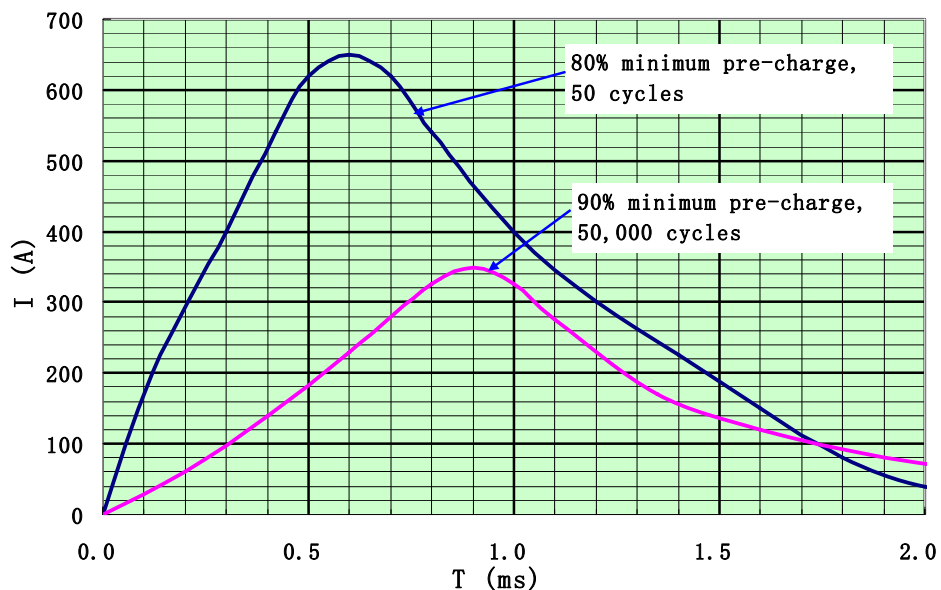
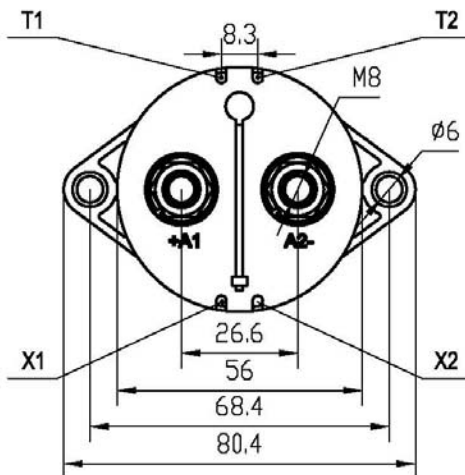
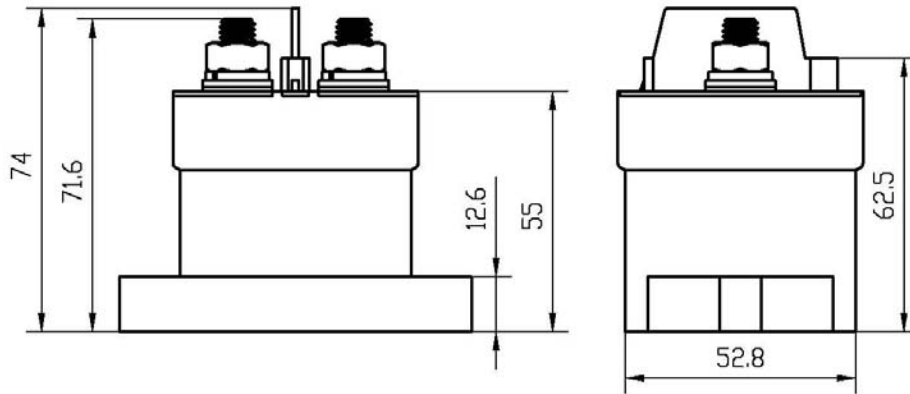

Figure 3. Make test curves for pre charged capacitive load at 320VDC

● **Outline dimension**



MOUNTING

M5 SCREWS TORQUE 1.7-4Nm

POWER TERMINAL

M8X1.25 HARDWARE INCLUDED

TORQUE 9-10Nm

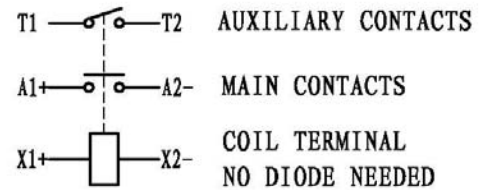

TERMINAL SCHEME

● **Application Information:**

1. **WARNING** - When using more than one lug on a power terminal, make sure the primary power is closest to the contactor busbar, with the lower current lug on top, then the washer, then the lock washer, then the nut. **Improper order can cause severe over-heating resulting in the possible melting of the connecting cable insulation.**